

NO DOK	KG/BP05	PROFIL PERUSAHAAN	TGL AKTIF	01 Maret 2013
REVISI	03		HALAMAN	1 / 16

**PROFIL PERUSAHAAN****DAFTAR ISI :**

DAFTAR ISI

PENGESAHAN DOKUMEN

DISTRIBUSI DOKUMEN

RIWAYAT PERUBAHAN

I. PROFILE PERUSAHAAN

**PENGESAHAN DOKUMEN**

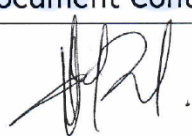
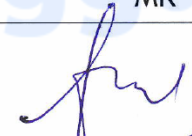
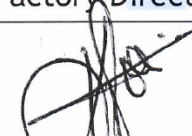
	Disusun oleh :	Diperiksa oleh :	Disetujui oleh :
Unit	Document Control	MR	Factory Director
Tanda Tangan			
Nama	Jalal Ichfani	Achid Syarif	Danau Kusman
Tanggal			

**DISTRIBUSI DOKUMEN**

Distribusi ke :

1. MR / Document Control	7. Personalia
2. Engineering R&D	8. Administrasi
3. Quality Assurance	9. IT
4. Produksi	10. WH
5. PPIC	11. Project MGT
6. Maintenance	12. Mouldshop

NO DOK	KG/BP05	PROFIL PERUSAHAAN	TGL AKTIF	01 Maret 2013
REVISI	03		HALAMAN	2 / 16

**RIWAYAT PERUBAHAN**

REV	BAB	HAL	URAIAN REVISI	DISETUJUI	TANGGAL
01	I	4	- Penambahan sejarah produk perusahaan dan Penambahan item fasilitas uji		18-05-2012
02	I	13	- Perubahan data tenaga kerja		08-01-2013
03	I	1	- Penambahan kolom pengesahan , Penambahan Distribusinya (WH, Project MGT, Mouldshop), dan penambaha alat-alat uji		01-03-2013

**CONTROLLED**  
DATE 01/03/13

NO DOK	KG/BP05	PROFIL PERUSAHAAN	TGL AKTIF	01 Maret 2013
REVISI	03		HALAMAN	3 / 16

## 1. PROFIL PERUSAHAAN PT. KENCANA GEMILANG

### 1.1 Alamat / Address

**Pabrik :**

Address : Jl. Raya Serang Km 16.8, Desa Talaga, Kecamatan Cikupa  
Kabupaten Tangerang, Banten 15710, Indonesia

Phone : (62-21) 5960203, 5960204

Fax. : (62-21) 5960205

Website : <http://www.miyako-mfg.com>

Email : [miyako@cbn.net.id](mailto:miyako@cbn.net.id)

PT. Kencana Gemilang didirikan pada tanggal 7 Februari 1987., dengan surat Akte Pendirian Notaris Sukmawaty Sumardy no 8 , Saat ini telah berkembang sehingga memiliki luas bangunan 84.425,72 m2 dan tanah seluas 14,3 Hektar. Jumlah karyawan 1720 orang.

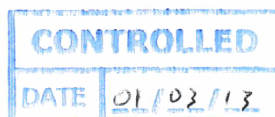

NO DOK	KG/BP05	PROFIL PERUSAHAAN	TGL AKTIF	01 Maret 2013
REVISI	03		HALAMAN	4 / 16

## 1.2 Sejarah Produk Perusahaan

- 1987 : - Rice Cooker (Conventional Type)
- 1990 : - Pressure Cooker, Weight Scale
- 1991 : - Fire Hidrant Box (Specific for Japan Market)
- 1994 : - Blender (Series 1)
  - Water Heater
  - Water Filter
- 1997 : - Rice Cooker (Jar Type), "3 in 1", Rice Warmer
- 1999 : - Electric Iron
- 2000 : - Rice Cooker (Jar Type), "3 in 1"
  - Blender (Series 1.5), "Big Capacity"
- 2002 : - Water Dispenser
- 2003 : - Chopper Blender
  - Lunch Box & Picnic Pack
- 2004 : - Electric Fan
  - Frying Fan
- 2005 : - Electric Fan & Electric Desk Fan
  - Water Dispenser (Standing Type & Big Capacity)
  - Stand Mixer
- 2006 : - Electric Pressure Cooker
  - Blender (Locking Type)
  - Rice Box (Knock Down)
- 2008 : - Rice Cooker Sanyo
  - Electric Fan Sanyo
- 2009 : - Water Dispenser (Extra Hot)
  - Water Dispenser Sanyo
  - Electric Fan (Emergency Lamp)
  - Electric Fan Tejari (Stand, Desk, Wall)
- 2010 : - Emergency Lamp
  - Electric Iron (Ceramic Coating)
  - Water Dispenser (Tank Assy Roll)
- 2011 : - Industrial Fan
- 2012 : - Commercial Blender
  - Industrial Fan (Wall / Desk Fan )
  - Industrial Fan (Stand Fan)
  - Magic Com (Batik)
  - Magic Com (Big Capacity)
  - Magic Warmer (Big Capacity)

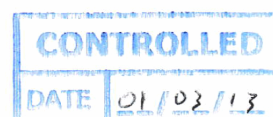

## 1.3 Produk dan Pasar

PT Kencana Gemilang merupakan Perusahaan manufaktur yang memproduksi alat-alat rumah tangga berupa Magic Com, Magic Warmer, Rice Cooker, Pressure Cooker, Blender, Mixer, Juicer, Water Dispenser, Rice Box, Electric Fan, Electric Iron, Weight scale, Fire Hydrant Box, Regulator, Selang regulator dll.

NO DOK	KG/BP05	PROFIL PERUSAHAAN	TGL AKTIF	01 Maret 2013
REVISI	03		HALAMAN	5 / 16

➤ **Rice Cooker**



**Water Dispenser**

CONTROLLED  
DATE 01/02/13



**Electric Fan**



NO DOK	KG/BP05	PROFIL PERUSAHAAN	TGL AKTIF	01 Maret 2013
REVISI	03		HALAMAN	6 / 16

**Blender**



**Chopper Blender**



**Hair Dryer**



**Mixer**



**CONTROLLED**  
DATE 01/03/13

**Rice Box**



**Pressure Cooker**



**Electric Iron**



**Weight Scale**



**Fire Hidrant Box**



**Regulator & Selang Regulator**



**Emergency Lamp**



**Sandwich Toaster**



**Industrial Fan**

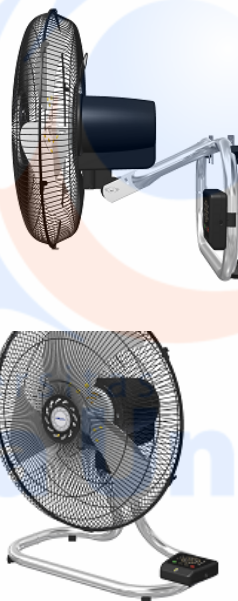

**MCM Batik**



**Big Capacity**



CONTROLLED  
DATE 01/02/13



NO DOK	KG/BP05	PROFIL PERUSAHAAN	TGL AKTIF	01 Maret 2013
REVISI	03		HALAMAN	9 / 16

PT Kencana Gemilang merupakan perusahaan manufaktur untuk mensupply perusahaan distributor satu grup yaitu PT BIT untuk semua penjualan lokalnya, sedangkan untuk penjualan ekspornya dilakukan sendiri melalui kerjasama dengan beberapa buyer dari luar negeri. Penjualan produk untuk pasar international telah di ekspor ke negara negara seperti Malayasia, Brunei Darusalam, Bangladesh, UEA, Madagascar, Vietnam, Thailand, Singapore dan Papua Nugini, dengan di Assembly oleh PT. Mitra Citra Makmur.

#### 1.4 Peran dalam Bisnis

Sejalan dengan perkembangan & pertumbuhan Distributornya PT BIT, PT.Kencana Gemilang sebagai perusahaan manufaktur bertugas untuk::

- ❖ Merencanakan pembuatan produk-produk baru dan perbaikan produk produk lama sesuai dengan permintaan pasar atau analisa trend perkembangan produk yang ada di pasar.
- ❖ Melaksanakan proses produksi untuk semua produk yang dipesan oleh BIT maupun perusahaan lainnya atas persetujuan BIT.

Beberapa aktivitas yang telah dilaksanakan antara lain berupa :

- ❖ Pengembangan produk baru dari semua lini produk yang dijual dengan merk Miyako yang dipesan oleh BIT maupun merk lain yang dipesan customer lainnya atas persetujuan BIT yaitu MCM, MJ, RC, PC, BL, MIXER, JUICER, CHOPPER, WATER DISPENSER, RICE BOX, EI, WS, WF, KAS, KAD, KAW, KET, KEC, FHB, OVEN TOASTER, REGULATOR, SELANG REGULATOR dll.
- ❖ Pengembangan bahan bahan baku, proses produksi, teknologi, sumberdaya manusia, sehingga mendorong efisiensi di segala bidang agar diperoleh keuntungan yang optimal sehingga selalu dapat berhasil dalam setiap kompetisi produk di pasar.
- ❖ Pengembangan organisasi, system manajerial dan standard standard produk internasional yang dipersyaratkan oleh perdagangan baik lokal maupun internasional mengikuti perkembangan zaman seperti diantaranya SNI, ISO 9001 :2008, TUV, SIRIM, ISO 14001, CB test, TISI dll.
- ❖ Perbaikan fasilitas pabrik, kantor, kantin, mushola dan pergudangan untuk menunjang kelancaran kegiatan perusahaan termasuk pengembangan pabrik diluar lokasi yang sekarang, sehingga menambah quantity produk yang akan dihasilkan..
- ❖ Peningkatan kerjasama dengan sub kontraktor local dan internasional guna pengadaan spare part dan assembling produk sehingga memudahkan pengadaan part serta pengendaliannya

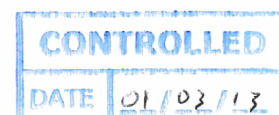

## 1.5 Fasilitas Pabrik

Selain gedung, fasilitas pabrik yang dimiliki di Area Plastics Part making (Injection) adalah mesin Injections, Injection printing, Injection material mixing, Chysen, Chrusher injection part, Vaccum forming, Plastic welding, PU foam. Dan di Kelompok Metal part berupa Mesin Press, mesin-mesin Polesh, Machining, Welding, Grill, Painting line, Anodizing line, Hard Anodize, Non Stick Coating line. Mouldshop equipment berupa CNC drilling, Machining centre, Wire cut, EDM, Mesin bubut, Skrap, Grinding, Welding dll. Juga di area Assembling yaitu Assembling line, Computer network, Laboratory equipment, Maintenance equipment, Pengolahan limbah, Powder coating line 2 dan Powder coating line 3.

### Product Development (Design)



### Assembly Line



### Mold Shop



### Injection



### Press



### Non Stick Coating



### Anodize



### Painting



### Stuffing Area



**CONTROLLED**

DATE 01/03/13

NO DOK	KG/BP05	PROFIL PERUSAHAAN	TGL AKTIF	01 Maret 2013
REVISI	03		HALAMAN	11 / 16

**Ruang Meeting****Kantin / Joglo****Penyimpanan system rak****Mesjid****Die Casting Regulator****Proses Selang Regulator****Produksi Motor Assy****Produksi Grill**

CONTROLLED

DATE 01/02/13

NO DOK	KG/BP05	PROFIL PERUSAHAAN	TGL AKTIF	01 Maret 2013
REVISI	03		HALAMAN	12 / 16

**Produksi Hard Anodize**



**Produksi Painting A**



**Produksi Painting B**



**Produksi Painting C**



**CONTROLLED**  
DATE 01/03/13

NO DOK	KG/BP05	PROFIL PERUSAHAAN	TGL AKTIF	01 Maret 2013
REVISI	03		HALAMAN	13 / 16

## 1.6 Fasilitas Uji & Test Akhir dan Kalibrasinya

- ✧ Non Stick Coating Life Test
- ✧ Microswitch Life Test
- ✧ Mixer Switch Life Test
- ✧ Blender Switch Life Test
- ✧ Magic Com Life Test
- ✧ Valve Assy Life Test
- ✧ Life Test 320 (Chopper)
- ✧ Blender Life test
- ✧ Mixing Ceramic Coating
- ✧ Thickness meter test
- ✧ Aging machine
- ✧ Multi tester
- ✧ Powermeter
- ✧ Multi Tester
- ✧ Leakage Current Test
- ✧ Roughness Tester
- ✧ Hybride thermometer
- ✧ High Voltage Tester and withstand meter
- ✧ Surface Thermometer
- ✧ Deeping thermometer
- ✧ Infra red Thermometer
- ✧ Glass Thermometer
- ✧ Hardness tester untuk baja plastic dan karet
- ✧ Mesin Regulator Life Tester
- ✧ Mesin Constant Temperatur Chamber
- ✧ Mesin Analysis Balancer ( 1mg )
- ✧ Alat test uji ketahanan letup
- ✧ Alat Untuk uji ketahanan ozon
- ✧ Alat Uji tes kebocoran membran
- ✧ Uji tes kebocoran dalam air
- ✧ Performance Testboard



**Mesin Analysis Balancer ( 1mg )**

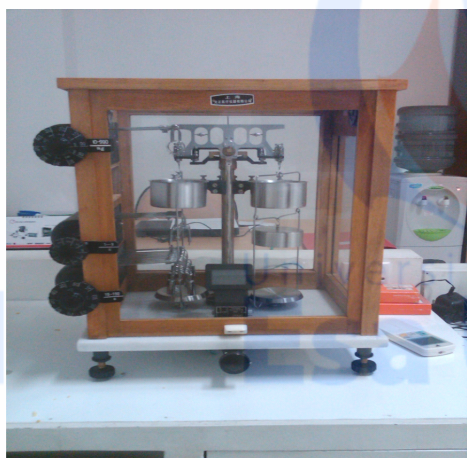

**Alat test uji ketahanan letup**



**Mesin Life Test Regulator**



**Mesin Life test Themperatur Chamber**



**Magic Com Life Test**

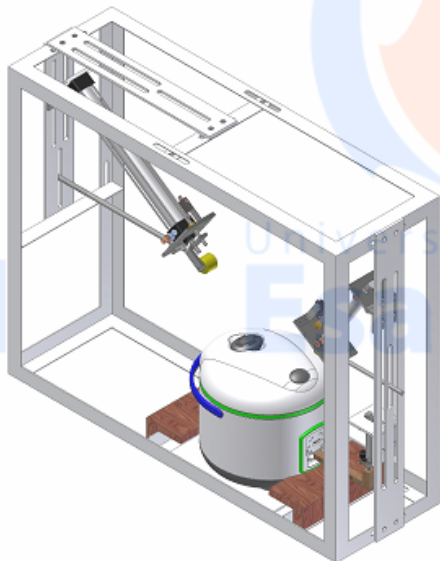

**Mixer Switch Life Test**

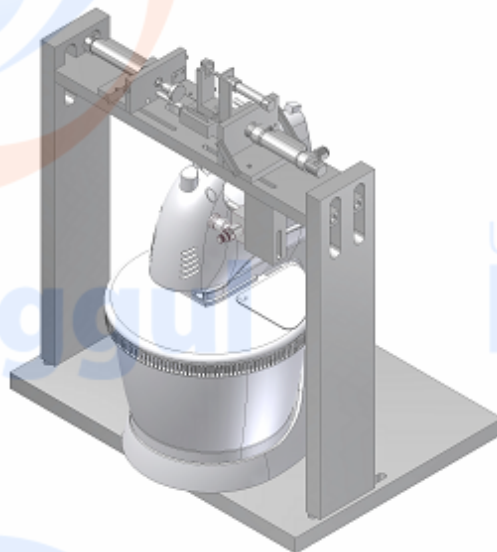

**Switch Life Test**

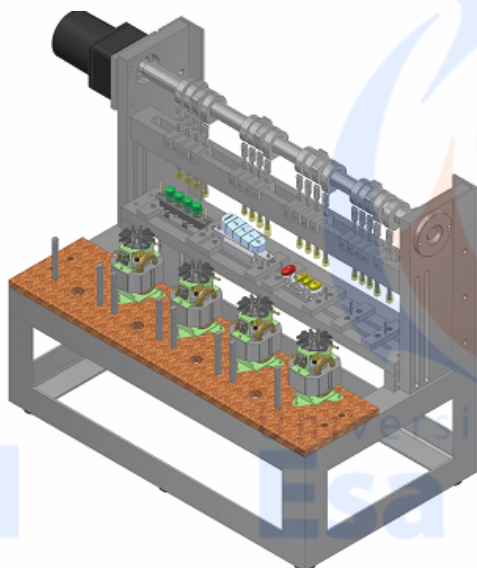

**Microswitch  
Life Test**

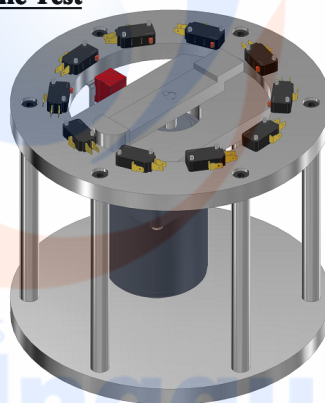

**Non Stick Coating  
Life Test**

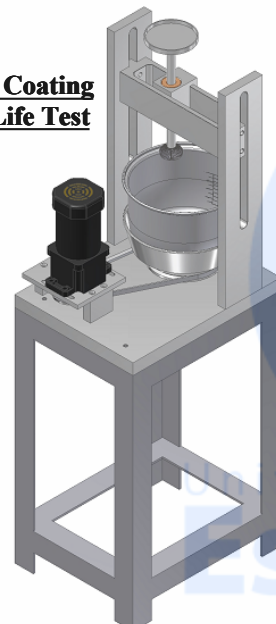

**Valve Assy  
Life Test**

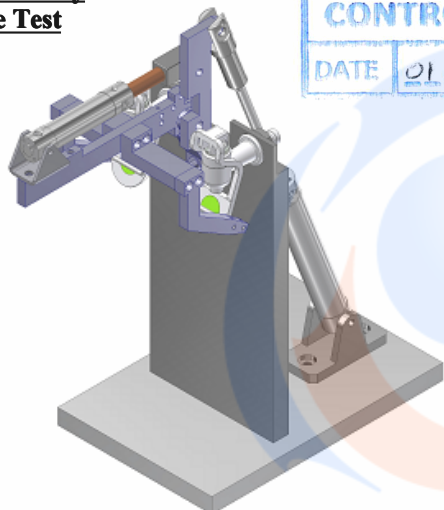

CONTROLLED  
DATE 01/02/13



**Mesin CNC**



**Mesin EDM**



**Mesin Wire Cut**



**Alat Uji Kekuatan Bahan**



**Alat Uji Cuaca**

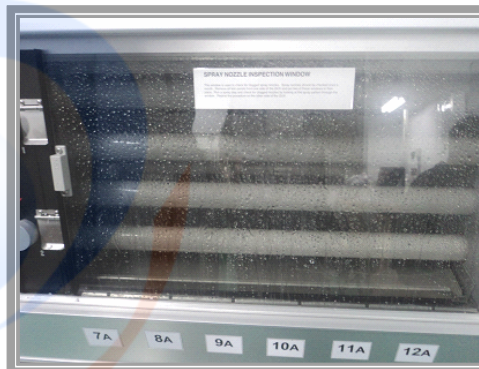

**CONTROLLED**  
DATE 01/03/13

NO DOK	KG/BP05	PROFIL PERUSAHAAN	TGL AKTIF	01 Maret 2013
REVISI	03		HALAMAN	16 / 16

### 1.7 Pengembangan Bisnis

Selain di dalam area pabrik inti di Cikupa PT. Kencana Gemilang juga melakukan pengembangan pabrik di luar lokasi tersebut yaitu di China, di Cikupa Mas, di Medan dan di Gresik Jatim untuk assembling produk, dalam rangka menambah kapasitas serta mengurangi biaya angkutan barang jadi terutama produk-produk yang volumenya besar.

### 1.8 Tenaga Kerja

Jumlah Tenaga kerja data sampai dengan Februari 2013 adalah 1677 orang, dibagi menjadi beberapa bagian, diantaranya :

PGA	=	94 orang
Maintenance	=	65 orang
Mouldshop	=	53 orang
Quality Control	=	150 orang
Scurity	=	44 orang
Admin	=	49 orang
IT	=	4 orang
Produksi	=	977 orang
PPIC	=	163 orang
Engineering PD	=	43 orang

### 1.9 Jam Kerja / Working Hour

Waktu kerja diatur sebagai berikut :

- Di area Injection dan Metal part :
  - Shift I : Jam kerja dari jam 7.00.00 s/d 15.00
  - Shift II : Jam 15.00 s/d jam 11.00
  - Tetapi jika dibutuhkan ada OT jam 7.00 s/d 19.00 (Shift I) dan jam 19.00 s/d jam 7.00 untuk (Shift II).
- Di area Assembly hanya satu shift dari jam 7.00 s/d jam 15,00 dan jika dibutuhkan ditambah dengan OT sampai dengan jam 17.00.

